



**TAMIL NADU TEXTBOOK AND EDUCATIONAL  
SERVICES CORPORATION**

**TENDER DOCUMENT**

**FOR**

**SUPPLY AND DELIVERY OF WOODEN COLOUR PENCILS TO  
SCHOOL CHILDREN IN TAMIL NADU ON ANNUAL RATE  
CONTRACT BASIS**

**For the year 2017-2018**

1.	<b>ADVERTISED ON</b>	:	<b>20.05.2017</b>
2.	<b>PRE-BID MEETING</b>	:	<b>06.06.2017 at 03.00 p.m</b>
3.	<b>LAST DATE &amp; TIME FOR SUBMISSION OF TENDER</b>	:	<b>22.06.2017 up to 03.00 p.m</b>
4.	<b>DATE &amp; TIME OF OPENING OF TECHNICAL BIDS</b>	:	<b>22.06.2017 at 03.30 p.m</b>

**TAMILNADU TEXTBOOK AND EDUCATIONAL SERVICES CORPORATION**

D.P.I. Campus,  
College Road,  
Chennai – 600 006.  
Tamil Nadu, India  
Phone: 28275851, 28278244  
Fax : 28224493

**Email: [mdtntbc07@hotmail.com](mailto:mdtntbc07@hotmail.com), [secytnbc@hotmail.com](mailto:secytnbc@hotmail.com)**

**Website: <http://www.textbookcorp.tn.nic.in>**

**TENDER DOCUMENT****FOR****SUPPLY AND DELIVERY OF WOODEN COLOUR PENCILS TO THE SCHOOL  
CHILDREN IN TAMILNADU ON ANNUAL RATE CONTACT BASIS.****TABLE OF CONTENTS**

<b>Sl. No.</b>	<b>Subject</b>	<b>Page No.</b>
1.	Scope of Tender	3
2.	Notice Inviting Tender	4-5
3.	Special Instructions and Check List	6-9
4.	Instructions to the Bidders (ITB)	10-26
5.	Special Conditions of the Contract	27-36
6.	Letter of Tenderer	37-39
7.	Technical Specifications ( <b>Annexure I</b> )	40
8.	Drawings ( <b>Annexure II – III</b> )	41-44
9.	Statements, Declarations and Formats ( <b>Annexure IV – XIV</b> )	45-57
10.	Price Bid	58

**TAMIL NADU TEXT BOOK AND EDUCATIONAL SERVICES CORPORATION**

**1. SCOPE OF TENDER**

**Supply and Delivery of Wooden Colour Pencils at Block Level**

In order to implement the announcements of the Hon'ble Chief Minister pertaining to the Scheme of Supply of cost-free Wooden Colour Pencils (one box of 6 wooden Colour Pencils (bicolour) each) to the School Children studying in Government & Aided Schools in Tamil Nadu for the year 2017-18, the Tamil Nadu Text Book and Educational Services Corporation, hereinafter, called as the Corporation, has been entrusted with the task of procuring quality Wooden Colour Pencils and distributing the same in time to the school children in accordance with the procedures laid down in the Tamil Nadu Transparency in Tenders Act, 1998 and the Tamil Nadu Transparency in Tenders Rules, 2000 as amended from time to time.

The Tamil Nadu Text Book and Educational Services Corporation has proposed to procure 15.48 **lakh** boxes of Wooden Colour Pencils (each box containing 6 wooden colour pencils bicolour) as per the specifications laid down in the Tender Document.

The successful Tenderer shall be empanelled as part of the rate contract and shall supply the boxes of Wooden Colour Pencils at the 480 designated locations viz 413 Blocks of AEEOs and 67 Education District Head Quarters and make replacement of the defective procured Wooden Colour Pencils in the manner specified in the Tender.

The Tamil Nadu Transparency in Tenders Act, 1998 and the Tamil Nadu Transparency in Tenders Rules, 2000 shall apply to this Tender.

The successful Tenderer shall work closely with the Government of Tamil Nadu and the Tamil Nadu Text Book and Educational Services Corporation in achieving the scheduled targets.

TAMILNADU TEXTBOOK AND EDUCATIONAL SERVICES CORPORATION,  
CHENNAI-600 006.

Phone: 044-28275851, 044-28278244  
Fax No: 044-28224493, 044-28241116  
E.mail: [mdtntbc07@hotmail.com](mailto:mdtntbc07@hotmail.com)

“EVK Sampath Maaligai”  
No.68, College Road,  
Chennai-600 006.

**2.NOTICE INVITING TENDER**

Rc.No. 7423/C1/2016

Sealed Tenders are invited from the manufacturers of Wooden Colour Pencils (**each Box containing 6 Wooden Colour Pencils bicolour**). National Competitive Bidding will be conducted under two cover system confirming to Tamil Nadu Transparency in Tenders Act, 1998 and Tamil Nadu Transparency in Tenders Rules, 2000.

1	Description of Tender	:	Supply and delivery of 15.48 lakh Boxes of Wooden Colour Pencils for School Children in Tamil Nadu on Annual Rate Contact Basis.
2	Cost of Tender Document	:	Rs.10,500/- inclusive of 5% VAT. Payable in the form of Demand Draft drawn from a Nationalised/Scheduled Bank in favour of <b>“Tamilnadu Textbook and Educational Services Corporation”</b> payable at Chennai.
3	Tender Documents Available at	:	Tamil Nadu Textbook and Educational Services Corporation, EVK Sampath Maaligai, 68, College Road, Chennai-600 006.  The same may also be downloaded free of cost from the following websites: a) <a href="http://www.textbookcorp.tn.nic.in">http://www.textbookcorp.tn.nic.in</a> b) <a href="http://www.tenders.tn.gov.in">http://www.tenders.tn.gov.in</a>
4	Sale period of Tender Document	:	On all working days from 20.05.2017 to 21.06.2017 between 10.00 a.m and 5.00 p.m.
5	Earnest Money Deposit (EMD)	:	Rs.1.27 lakhs.
6	Date of Pre-Bid Meeting	:	06.06.2017 at 03.00 p.m

7	Last Date and Time for Submission of Tender	:	22.06.2017 up to 03.00 p.m
8	Due date and time for opening of Technical Bids	:	22.06.2017 at 03.30 p.m
9	Contract Period	:	One year from the date of entering into agreement.

**Consortium bids are not acceptable. For all other conditions / instructions please refer tender document.**

The Corporation shall not be responsible for any postal delay or any loss of Tenders in transit. The Managing Director, Tamil Nadu Text Book and Educational Services Corporation reserves the right to amend or withdraw any of the Terms and Conditions in the Tender Document or to cancel / reject all the tenders received without giving any notice or assigning any reason.

The Tenderers are requested to view the above Websites for any changes / amendments / corrigendam in the Tender which may be issued before the last date for submission of the Tender.

Managing Director and  
Tender Inviting Authority,  
Tamil Nadu Text Book and Educational  
Services Corporation.

**3. Special Instructions for submission of Technical Bids &  
CHECK LIST**

1. All pages of the Technical Bid should be signed by authorized signatory whose name should be communicated to the Corporation with office seal without any omission.
2. The notarized copies of performance certificate and Bankers certificates enclosed for the bids should be identified as the documents submitted by the bidder over the signature with office seal.
3. Any document / credential submitted without signature of authorized persons will not be considered for evaluation.
4. Bidder should produce the originals for the performance / client certificate for verification when ever required with the copies of those certificates enclosed along with the bid.

**CHECK LIST****TENDERERS SHALL FILL IN THE CHECK LIST GIVEN BELOW****I. PART – A COVER – (TECHNICAL BID)**

<b>SL. NO.</b>	<b>DESCRIPTION</b>	<b>Please State Yes or No in writing</b>	<b>Please indicate the relevant page no.</b>
1.	Whether the Tender is submitted in two envelopes as Part-A Cover (Technical Bid) and Part-B Cover (Price Bid)?		
2.	Whether Letter of Authorization / Power of Attorney for signing the Tender Document is enclosed on a Non-Judicial Stamp Paper of value of not less than Rs.20/-?		
3.	Whether Earnest Money Deposit (EMD) of Rs.1.27 lakhs/-(Rupees One Lakh and twenty seven thousand only) in the form of Demand Draft/ Banker's cheque drawn on any Nationalised Bank in favour of the "Tamil Nadu Text Book and Educational Services Corporation, Chennai," payable at Chennai is enclosed?		
4.	Whether Profile of the Company as per Annexure IV is enclosed?		
5.	Whether Audited Balance sheet duly certified and the Annual Turnover certificate as per Annexure - V is enclosed?		
6.	Whether the statement of supply orders executed during the past three years in Annexure VI is enclosed.		
7.	Whether Declaration in Annexure – VII for not having been blacklisted either by Tamil Nadu Text Book and Educational Services Corporation or by any other Govt. / Govt. undertaking is enclosed?		
8.	Whether Declaration in Annexure – VIII duly signed by the Tenderer is enclosed?		
9.	Whether a Self Certificate of Quality in Annexure – IX is enclosed?		
10.	Whether a Certificate in Annexure – X assuring to supply the minimum quantity prescribed in		

	the Tender is enclosed?		
11.	Whether a Declaration in Annexure XI that Tender forms downloaded from the website have not been tampered is enclosed?		
12.	Whether Banker's certificate of minimum cash credit facility as per Annexure XII is enclosed?		
13.	Whether Terms and Conditions of the Tender in original are duly signed in each page of the Tender Document?		
14.	Whether a Video CD covering the entire manufacturing process of the Company from the raw material stage to the finished product is furnished?		
15.	Whether documentary proof for manufacturing of the Wooden Colour Pencils at least for the last three years has been enclosed?		
16.	Whether a list of Lab Equipments available in the Tenderer's manufacturing Units is furnished?		
17.	Whether a list of Plant and Machinery available in the Tenderer's manufacturing units is furnished?		
18.	Whether documentary evidence in support of the production capacity of the Tenderer is enclosed?		
19.	Whether Photo copy of the latest Income Tax Return duly signed by the Auditor is enclosed?		
20.	Whether duly attested Photo copy of the Certificate of Registration under VAT/CST is enclosed?		



**II. PART – B COVER (PRICE-BID)**

<b>SL.NO</b>	<b>DESCRIPTION</b>	<b>Please state Yes or No in writing</b>
1.	Whether Price-Bid in Part B duly filled-in and signed is enclosed?	

## 4. INSTRUCTIONS TO THE BIDDERS (ITB)

### 1. General Instructions:

The Bidders are requested to go through the instructions, terms, conditions and specifications given in the Tender Document carefully. Omissions or Failure to furnish any or all the required information in the Tender Document shall result in rejection of their bid.

### 2. Definition of Terms and Expansion of Abbreviations :

1.	Tenderer/Bidder	Tenderer / Bidder means the party who makes a formal offer in pursuance of this tender.
2.	Successful Tenderer	Successful Tenderer means the Tenderer who becomes successful through the tender process and whose offer is accepted by the Corporation.( at the price arrived at by the Corporation after negotiation with L1).
3.	Manufacturer	Manufacturer means the firm which manufactures the Wooden Colour pencils.
4.	Day	A day means a calendar day.
5.	Cost / Price Bid	Cost means the total cost to be incurred by the Corporation towards the purchase of Wooden Colour Pencils. The cost should be all inclusive.
6.	Purchaser	Purchaser means the Tamil Nadu Text Book and Educational Services Corporation.
7.	Delivery Point	Delivery point means designated location at Block Head Quarters (No.of Blocks:413) (No.of Education Districts: 67) in the State of Tamil Nadu.
8.	TNTB & ESC	Tamil Nadu Text Book and Educational Services Corporation
9.	Wooden Colour Pencil	Single edge colour pencil made up of wood with lead bonded with wax used for colouring and drawing.
10.	Box of Wooden Colour Pencils	A carton box containing 6 Wooden Colour Pencils (bicolor) in two rows.
11.	EMD	Earnest Money Deposit
12.	SD	Security Deposit

### 3. Bid Document:

The Bid Document consists of the following

1. Scope of Tender
2. Notice Inviting Tender
3. Special Instructions for submission of bids & Check list
4. Instructions to the Bidders
5. Special Terms & Conditions of the Tender
6. Letter of Tenderer
7. Specifications
8. Drawings
9. Statements, Declarations and Formats
10. Price Bid.

### 4. Qualification Criteria:

4.1. The Tenderer shall be a **Manufacturer of Wooden Colour Pencils** at least for a period of the last 3 years as on 31.03.2017 and he shall possess valid registration for the manufacture Wooden Colour Pencils. **(Copy of valid Certificate of Registration under the relevant laws should be enclosed).**

4.2. **Turnover :**

The average annual turnover of the bidder during any three consecutive financial years from 2012-13 to 2015-16 shall not be less than Rs. 50.00 lakhs. **(Attach certificate from Chartered Accountant along with audited balance sheet and profit & loss statement for the last three financial years).**

4.3. **Production Capacity:** The Tenderer shall have the manufacturing capacity with the required minimum Plant, Machinery, Manpower and Laboratory Equipments at the manufacturing units to manufacture at least 5,000 boxes of Wooden Colour Pencils per day. The Tenderer shall also have the facility for testing the quality of the Wooden Colour Pencils to be supplied.

4.4. **Minimum Quantity to be offered:** The Tenderer should offer to supply not less than 1.50 lakhs boxes of Wooden Colour Pencils within the contract period of 60 days.

4.5. **Past Experience:** The Tenderer should have supplied at least 5% of the tendered quantity of 15.48 lakh boxes. (80,000 boxes) of Wooden Colour Pencils in any one of the last 3 years prior to 31.03.2017. **(Supporting documents including invoices shall be enclosed along with the Tender. A detailed abstract of the invoices for the quantity supplied should also be enclosed. Invoices shall be compulsory submitted as part of the supporting documents).**

4.6. **Credit Facility:** The Tenderer shall have a minimum cash credit facility of Rs. 50.00 lakhs (Rupees Fifty lakhs) exclusively for this work duly certified by the Banker. **(The original certificate in the prescribed format issued by the Nationalised/Scheduled Bank should be enclosed).**

4.7. **Samples adhering to Specifications:** The Tenderer shall furnish the required samples confirming to the specifications prescribed.

#### **5. Change in Quantity:**

Quantity given in the Notice Inviting Tender is approximate and it is likely to vary. The Corporation, if necessary, at the time of placement of purchase order shall modify, reduce or increase the quantity mentioned in the tender to the extent of 25%.

#### **6. Pre-Bid Meeting:**

There will be a **Pre Bid meeting on 06.06.2017 at 03.00 pm in the Tamil Nadu Text Book and Educational Services Corporation, DPI Campus, Chennai 600006** during which the prospective Tenderers may seek clarifications about the Tender. The Tenderers shall send their queries in writing if any so as to reach the Corporation at least two days prior to the date of Pre-Bid Meeting. The Tenderers shall view the Websites given in the Notice Inviting Tender for updated information like change in date / venue etc., of the Pre-Bid

meeting as the Corporation may not be able to identify and communicate with the prospective Bidders at this stage. Failure to attend the Pre-Bid meeting is not a disqualification as it is optional. In response to the relevant query of the prospective Tenderer, clarification will be given in writing. Only the clarifications given officially shall be valid.

#### **7. Clarification regarding the Tender Conditions:**

- 7.1. A prospective Bidder requiring any clarification with respect to any Tender condition may address the Tender Inviting Authority by letter and he will respond in writing to any relevant query regarding the Tender conditions. However correspondence in this regard or delay in getting reply from the Corporation shall not be taken as an excuse for delayed submission of tender or non submission of tender.
- 7.2. The clarifications to the relevant queries will also be uploaded on the website of the Corporation.

#### **8. Amendments to the Tender:**

8.1. Tamil Nadu Text Book and Educational Services Corporation reserves the right to amend the tender condition on the basis of clarifications sought for by the prospective Bidders, solely at its discretion upto 48 hrs before 22.06.2017 (i.e) two days prior to the last date of submission of Tender. Such amendments shall be uploaded on the Websites: <http://www.tenders.tn.gov.in>. & <http://www.textbookcorp.tn.nic.in>

8.2. Any addendum/clarifications thus issued shall be part of the bidding documents and shall be communicated in writing / e-mail to all the purchasers of the bidding documents. Prospective bidders shall acknowledge receipt of each addendum.

8.3. At its discretion the Corporation may or may not extend the due date and time for the submission of bids on account of amendments / corrigendum, if any, issued subsequent to the date of Notice Inviting Tender.

8.4.All the Bidders must periodically browse the above website for any amendment or corrigendum issued in connection with this Tender. The Tamil Nadu Text Book and Educational Services Corporation will not be responsible for the failure of the Tenderer to update or to have comprehensive understanding of the provisions of this tender document including the changes announced through the website.

**9. Language of the Bid:**

The bid prepared by the Bidder as well as all correspondence and documents relating to the bid shall be written in English language only.

**10. Non Transferability:**

The Tender Document sold to a Tenderer is not transferable. It shall not be used by others and if used by others it will be rejected. Similarly photo copy of the tender Document will be rejected.

**11. Downloading of Tender Document:**

11.1. The tender document can be downloaded from the websites <http://www.tenders.tn.gov.in> (or) <http://www.textbookcorp.tn.nic.in> on A4 size paper and computer print alone should be submitted in the form of a booklet. Submission of tender document in any other form will be rejected.

11.2.The Tenderer shall download corrigendum, if any, published subsequently and submit along with the tender. It is the responsibility of the Tenderer to check and have knowledge of any corrigendum / amendment issued and uploaded on the website of Corporation.

11.3.The Tenderer shall download tender documents in original without any change / addition / deletion and correction. If any change / addition / deletion is detected at any stage after the award of the tender, the EMD as well as S.D remitted by the Tenderer will be forfeited without any intimation and the Tenderer will also be black listed from participating in the subsequent tenders. Besides such Tenderers are liable to be prosecuted.

**12. Cost of Tendering:**

The Tenderer shall bear all costs involved in the preparation and submission of tender and the Corporation shall in no case be responsible or liable for the costs of tendering incurred by the Tenderer, irrespective of the outcome of the tenders.

**13. Bid Validity**

13.1. Bid shall remain valid for a period not less than **one hundred and twenty days (120days)** after the deadline date for bid submission specified. **A bid valid for a shorter period shall be rejected by the Corporation as non-responsive.**

13.2. In exceptional circumstances, the Corporation may request the bidders to extend the period of validity for a specified additional period. The request and the bidder's responses shall be made in writing or e-mail. A bidder may refuse the request without forfeiting his bid security (EMD). A bidder agreeing to the request will not be required or permitted to modify his bid, but will be required to extend the validity of his bid security for a period of extension.

**14. Earnest Money Deposit (EMD):**

1. An Earnest Money Deposit of Rs. 1.27 lakhs (Rupees one lakh and twenty seven thousand only) shall be paid along with the Technical Bid by way of Demand Draft / Banker's Cheque obtained from a Nationalized / Scheduled Bank drawn in favour of Tamil Nadu Text Book and Educational Services Corporation, Chennai -6 payable at Chennai.
2. The Earnest Money Deposit amount of the unsuccessful Tenderers will be returned after the award of the Contract pursuant to the selection of the successful Tenderer. The Earnest Money Deposit amount held by the Corporation, will not fetch any interest till it is refunded to the unsuccessful Tenderers.
3. The Earnest Money Deposit amount of the successful Tenderer can be adjusted against the Security Deposit (SD) payable for ensuring successful execution of the Contract.

4. Any tender not accompanied by Demand Draft or Banker's Cheque towards Earnest Money Deposit as in Sub-Clause 14.1 above shall be rejected summarily by the Corporation.
5. The Earnest Money Deposit amount shall be forfeited
  - (a) If a Tenderer withdraws the tender after opening of Technical Bid during the validity period specified in the tender document
  - (b) In the case of a successful Bidder, if the bidder fails to sign the agreement or to remit the Security Deposit within the specified time limit.
  - (c) If the bidder does not accept the correction of the bid price pursuant to clause 24(1).

## **15. Submission of Tender:**

### **15.1. Submission of Tender in Two Cover System :**

Tender shall be submitted in two parts in original i.e Part-A and Part-B. The Part-A cover shall contain the Technical Bid and superscribed on the envelope as "Part-'A'- Technical Bid"- "Tender for Supply and delivery of Wooden Colour Pencils on Annual Rate Contract basis". On the Part-A Cover, the Name and Address of the Tenderer shall be written and sealed. The tender document shall compulsorily be spiral bound & indexed with page numbers.

The Part-B Cover shall contain the Price-Bid- superscribed on the envelope as "Part-'B' Price Bid"- "Tender for Supply and delivery of Wooden Colour Pencils on Annual Rate Contract basis". On the Part B Cover, the Name and Address of the Tenderer shall be written and sealed.

Both the Covers i.e., Part-A and Part-B shall be put in an envelope superscribing thereon "**Tender for the Supply and delivery of Wooden Colour Pencils on Annual Rate Contract basis**" and the Name and Address of the Tenderer shall be written on that envelope and it shall be sealed. The sealed envelope addressed to the Tender Inviting Authority i.e. the Corporation shall be put in the box kept in the office of the Corporation within the scheduled time



and date of submission of the Tender. It may also be sent by Post so as to reach the office of the Corporation within the stipulated time and date of submission of the Tender. But the Corporation shall not be responsible for any postal delay or delay due to any other means of communication. Belated submission of Tenders by the Tenderers or belated receipt of Tenders by the Corporation shall result in summary rejection of such Tenders. If the last date scheduled for submission of the tender happens to be a Government holiday for any reason, the sealed tenders may be submitted on the next working day before the appointed time. Tender once submitted shall not be permitted to be altered or amended.

**15.2. Documents to be furnished in the Part – A Cover:**

- (a) Covering Letter.
- (b) Letter of Tenderer shall be duly signed by the authorized signatory in full with seal.
- (c) Crossed Demand Draft / Banker's Cheque towards EMD shall be enclosed only in the Part-A Cover. (Technical Bid).
- (d) Annexure I to XIV
- (e) Profile of the Company with a Video CD covering the entire manufacturing process of the Company from the raw materials stage to the stage of finished products.
- (f) Letter of Authorization / Power of Attorney for signing the Tender Document shall be on a Non-Judicial Stamp Paper of value of not less than Rs.20/-. In the case of Public Sector Undertaking / Public / Private Limited Companies, Authorization from the appropriate authority to sign the tender document must be enclosed along with Technical Bid. Tenders received without such authorization shall be rejected.
- (g) I.T. Returns for the period from 2012-13 to 2015-16. (Self attested Photo copies to be enclosed).
- (h) VAT and TIN Registration Number / CST and PAN Card (Self attested Photo Copies to be enclosed).

- (i) Complete Audited Profit and Loss & Balance sheet for the last three years 2013-14 to 2015-16. (Self attested Photo copies to be enclosed).
- (j) All the required documents for qualification criteria given in this tender along with other required documents and the enclosures as per the Check List shall be enclosed. (Self attested photo copies to be enclosed).
- (k) List of Plant and Machinery and Laboratory Equipments available at the Tenderer's manufacturing unit for manufacturing the Wooden Colour Pencils and the Colour Pencil Boxes and for conducting the Tests as per the specifications in the Tender Document. (Address proof for manufacturing unit for duly notarised to be enclosed)
- (l) The Tenderer shall submit 3 untested samples of Wooden Colour Pencils for testing. **(The samples shall be tagged with detachable Identity Card or Mark. No printing or writing with indelible ink on the sample is permissible)**

**15.3. Details to be furnished in the Part- B (Price Bid) cover:**

- (a) Covering Letter.
- (b) Bid Price for the work with each page signed, dated and stamped with the seal of the firm.
- (c) The offer shall be unconditional.
- (d) The price quoted shall be all inclusive and no additional claim on any ground shall be entertained.
- (e) Apart from the Schedule of Prices duly filled in, the Bidders shall not enclose any other documents or statements that influence the price except Discount/Rebate letter. In such an event, the Corporation shall summarily disqualify the Bidder and reject the Bid.

**15.4. Signing of Tender:**

- a) The tender shall be typed or written legibly in indelible ink and shall be signed by the Tenderer or a person duly authorized to bind the Tenderer to the contract. **All pages of the tender shall be signed by the Tenderer or person(s) authorized to sign the Tender with the seal.**

- b) The tender shall contain no alterations or additions, except those to comply with instructions issued by the Corporation or as necessary to correct errors made by the tenderer, in which case such corrections shall be initialed by the person or persons signing the tender.

**16. Extension of Period of Contract:**

The rates quoted in the Tender shall be valid for a period of **one** year from the date of execution of the agreement. However, the Managing Director of Tamil Nadu Text Book and Educational Services Corporation may extend the validity period for further one year on the same terms, conditions and with the settled rates.

**17. Mode of Submission of Samples:**

17.1. The Tenderers shall submit **three boxes of untested samples of Wooden Colour Pencils** manufactured as per the specifications given in the Tender Document along with Part- A Cover (Technical Bid). The samples of bidders will be retained by the Tamil Nadu Text Book and Educational Services Corporation.

17.2. Tenders received without samples shall also be summarily rejected.

**18. Modification and Withdrawal of Tenders:**

18.1. Tenderers may modify or withdraw their tenders by giving notice in writing before the due date for submission.

18.2. The modification or withdrawal notice shall be prepared, sealed, marked and delivered in accordance with clause 15, with the outer and inner envelopes additionally marked "MODIFICATION" or "WITHDRAWAL" as appropriate.

18.3. No tenderer shall be allowed to withdraw/modify the tenders after the last date of submission of the tender.

18.4. Withdrawal or modification of tender between the deadline for submission of tenders and the expiration of the original period of validity specified or as extended period may result in forfeiture of the EMD.

**19. Opening of Tenders:**

19.1. Tenders will be opened at the scheduled date and time in the office of the Corporation in the presence of the Tenderers or their representatives who are authorised to represent the Tenderers. The representatives of Tenderers who attend the Tender opening shall produce the proof of their identity and the authorization letter from the Tenderers. Only one representative is permitted to attend Tender opening on behalf of the Tenderer.

19.2. Tenders received after the due date and time will not be considered. Tenders in unsealed cover or Tenders which are not signed in each page or in incomplete shape or through facsimile (Fax) or by electronic mail or through any other manner which is not in accordance with the instructions specified in the Tender will not be accepted.

19.3. Envelopes marked Withdrawal shall be opened and readout first and their tender shall not be opened. Subsequently, all envelopes marked Modification shall be opened and the submission therein readout.

19.4. If the day fixed for opening of the tender happens to be a Government holiday for any reason, the sealed tenders shall be opened on the next working day at the appointed time.

19.5. Part- A cover containing Technical Bid shall be opened first. The supporting documents shall be cross-checked wherever required.

**20. Criteria for Evaluation of Technical Bid:**

Any Tender not containing the required documents and not fulfilling the qualification criteria indicated in the Tender document shall be summarily rejected.

20.1. Prior to the detailed evaluation of bids, the Employer will determine whether each Bid (a) meets the eligibility criteria (b) has been properly signed (c) is accompanied by the required EMD and (d) is substantially responsive to the requirements of the Bidding documents.

20.2. A substantially responsive bid is one which confirms to all the terms, conditions, and specifications of the tender documents, without material deviation. A material deviation or reservation is one (a) which affects in any

substantial way the scope, quality, or performance of the supply; (b) which limits in any substantial way, inconsistent with the tender documents, the Employer's rights or the Bidder's obligations under the contract; or (c) whose rectification would affect unfairly the competitive position of other bidders presenting substantially responsive bids.

**21. Sample Testing for Tender Evaluation:**

21.1. The Tenderer shall submit 3 samples of Wooden Colour Pencils manufactured as per technical specifications prescribed in the tender document. The samples shall be tested by the Corporation in any of the accredited laboratory, preferred by the Corporation.

21.2. The samples of the Wooden Colour Pencils shall be tested by the Corporation through any of the accredited laboratories.

- i. Quality tests in respect of the samples.
- ii. Whether the quality, size and dimension of the samples are in conformity with the Technical specifications prescribed in the Tender document.

21.3. The Corporation reserves the right to test the samples at its discretion and in the event of failure of the sample in the test, the tender shall be summarily rejected.

**22. Site Visit:**

22.1. The authorised representative of the Corporation shall visit the manufacturing units of the tenderers to verify the manufacturing capacity, the availability of the plant, machinery and manpower, the infrastructure facility including the quality testing, etc. Further the authorised representative shall inspect the original Certificates of Registration and Incorporation of the Company and the originals of all the relevant documents which the Technically Qualified tenderers filed along with the Tender.

22.2. If the report of the Field Inspection / Site Visit is adverse, the Tenderer shall be disqualified and the Price Bid of such Tenderer shall not be opened.

**23. Opening of Price Bid (Part - B Cover):**

- 23.1. Only the Price Bids of the Tenderers who are qualified in the Technical Bid shall be opened.
- 23.2. The date, time and venue of opening of Part - B Cover i.e. Price Bid will be intimated separately to the qualified eligible Tenderers.
- 23.3. The Price Bid will be opened on the intimated date and time in the presence of the Tenderers or their authorised representatives.

**24. Evaluation of the Price Bid:**

The Price Bid of the technically responsive tenders shall be evaluated and compared in accordance with the criteria specified. In the evaluation of the Price Bid, the following procedure shall be adopted as per Tamil Nadu Transparency in Tender Act 1998 and Tamil Nadu Transparency in Tender Rules 2000.

24.1. In determining the lowest evaluated price, the following factors shall be considered.

- a) the quoted price shall be corrected for arithmetical errors.
- b) in case of discrepancy between the prices quoted in words and in figures, lower of the two shall be considered.
- c) where there is a discrepancy between the unit and the line item total resulting from multiplying the unit rate by the quantity, the unit rate as quoted will govern,
- d) In the evaluation of the price of the goods which are subject to Central Duties and Central Excise Duty, the price shall be determined as inclusive of such Duties.
- e) the amount stated in the bid will be adjusted by the Corporation in accordance with the above procedure for the correction of errors and shall be considered as binding upon the bidder, If the bidder does not accept the corrected amount the bid will be rejected and the EMD may be forfeited.
- f) Provided that where more than one Tender is submitted by the same tenderer, the lowest eligible financial tender shall be considered for

evaluation.

24.2. In respect of Sales Tax / VAT where all the Tenderers are from within the State of Tamil Nadu or where all the Tenderers are from outside the State of Tamil Nadu, the Sales Tax / VAT shall be included for the evaluation of the Price Bid.

24.3. Where the Tenderers are both from the State of Tamil Nadu as well as from outside the State of Tamil Nadu, the Sales Tax / VAT in respect of the Tenderers from Tamil Nadu shall be excluded for the evaluation of the price as per the provisions laid down in Rule 29 (d) (iv) of the Tamil Nadu Transparency in Tenders Rules, 2000.

24.4. The Corporation is empowered to negotiate with the L1 Tenderer. In case where two or more tenderers quoted the same price, the Corporation shall negotiate with L1 bidders & if necessary arrive at final negotiated price for supply and delivery of Wooden Colour Pencils by entering into a rate contract with other technically qualified eligible Tenderers who match their price with the negotiated price of the L1 Tenderer.

24.5. The total quantity of the Wooden Colour Pencils to be ordered and procured may be apportioned among the L1 bidder and the other technically qualified eligible bidders whose price matches with the price of L1 Tenderer.

24.6. In the case where the quantity offered at the lowest price is less than the total quantity required, the Corporation after placing orders with the lowest evaluated tenderer for the entire quantity offered or 60% whichever is lower by such tenderer, subject to the ability to supply, negotiate with the next lowest tenderers in strict ascending order of evaluated price and require to match the price offered by the lowest evaluated tenderer and place orders until the entire quantity required is ordered.

24.7. The L1 Tenderer shall not claim from the Corporation that the entire quantity of the goods shall be procured from him. He/She shall not question or raise any dispute as to the propriety and decision of the

Corporation in apportioning the bulk quantity of the procurement as specified in sub clause 24.6 above.

24.8. All eligible suppliers who accept the L1 rate shall be enlisted by the Corporation for delivery of goods.

24.9. Where the Corporation deems fit, it may issue an advertisement indicating the rates fixed and call for enrolment of more suppliers at the L1 rate subject to such suppliers fulfilling the eligibility criteria.

**25. Approval of the Contract by the Board of Governors of the Corporation:**

The Contract shall be awarded only with the approval of the Board of Governors to the successful L1 Tenderer with whom negotiations were made. The apportionment of the bulk quantity of the goods to be procured as specified in **Clause 24.5** shall be done only with the approval of the Board of Governors. The Board of Governors of the Corporation is also the Appellate Authority.

**26. Right to Accept / Reject any or all Bids:**

The Tender Accepting Authority i.e the Board of Governors of the Corporation reserves the right to accept or reject any or all of the tenders including the lowest in full or in part without assigning any reasons thereof and without thereby incurring any liability to the Bidder or Bidders who may be affected financially or otherwise to this effect.

**27. Letter of Acceptance:**

The Managing Director of the Corporation shall issue the Letter of Acceptance (LOA) to the successful Tenderer(s).

**28. Payment of Security Deposit (SD):**

28.1. The Successful Tenderer shall be required to furnish Security Deposit equivalent to 5% (Five percent) of the value of the purchase order as a guarantee for the performance of the Contract. The EMD will be adjusted against the Security Deposit. After adjusting the EMD, the successful Tenderer shall pay the balance amount through Demand Draft within 10 days from the date of issue of Letter of Acceptance. The Demand Draft shall be obtained from



any one of the Nationalized Banks / Scheduled Banks drawn in favour of Tamil Nadu Text Book and Educational Services Corporation, Chennai - 600 006 payable at Chennai or in the form of unconditional irrevocable Bank Guarantee valid for eighteen months. Failure of the successful bidder to furnish the security deposit shall constitute sufficient grounds for cancellation of the award and forfeiture of the EMD. **No exemption will be allowed towards payment of Security Deposit under any circumstances.**

28.2. The Security Deposit shall be released to the Successful Tenderer after the performance of the Contract in full without deficiency or default and to the entire satisfaction of the Tamil Nadu Text Book and Educational Services Corporation. The Security Deposit so held by the Corporation, shall not earn any interest till it is released to the Successful Tenderer. The release of the Security Deposit is subject to the forfeiture clauses in the Tender Document.

28.3. The Security Deposit shall be forfeited if the Successful Tenderer fails to execute the agreement within the stipulated time or fails to perform the contract or part of the contract. The Security Deposit shall also be liable for forfeiture for violation of any of the tender conditions or for the failure to supply the ordered quantity of goods in full properly and promptly.

### **29. Execution of Agreement:**

29.1. The successful Tenderer shall execute the Agreement for the fulfillment of the Contract on a Non-Judicial Stamp Paper to the value of Rs.20/- within 15 days from the date of issue of the Letter of Acceptance (LOA) of the Contract. The Agreement shall be part and parcel of the Contract and binding on the Corporation and the Successful Tenderer. In case of any difference or contradiction in the recitals in the Tender Document and the Agreement, the recitals in the Agreement shall prevail over those in the Tender Document.

29.2. The Successful Tenderer shall not assign or make over the Contract, the benefit or burden thereof to any other person or persons or Body Corporate for the execution of the Contract or any part thereof.

**30. Interpretation:**

If any question / doubt arise with reference to the interpretation of any provisions of the Tender Document, the decision of the Managing Director of the Corporation shall be final and binding.

**31. Corrupt and Fraudulent practices:**

The Corporation requires that Bidders observe the highest standard of ethics during the evaluation and execution of supply.

31.1. In pursuance of this policy, the Corporation defines for the purposes of this provision the terms set forth below as follows:

(i) 'Corrupt practice' mean offering, giving, receiving or soliciting of anything of value to influence the action of a public official in the evaluation process or in contraction execution.

(ii) 'Fraudulent practices' means a misrepresentation of facts in order to influence the evaluation process or execution of a contract / supply to the detriment of the Corporation and includes collusive practice among bidders (prior to or after bid submission) designed to establish bid prices at artificial, non competitive levels and to deprive the Corporation of the benefits of free and open competition.

31.2. Will reject a proposal for award if it determines that the Bidder recommended for award has engaged in corrupt or fraudulent practices in competing for the contract in question.

31.3. Will declare a firm ineligible either indefinitely or for a stated period of time to be awarded a contract if it any time determines that the firm has engaged in corrupt and fraudulent practices in competing for or in executing the contract.

## **5. SPECIAL TERMS AND CONDITIONS OF THE TENDER**

1. The Special Terms and Conditions of the Tender shall supplement the "INSTRUCTIONS TO THE BIDDERS".
2. The time and date of supply and delivery of boxes of Wooden Colour Pencils stipulated in the purchase order shall be deemed to be the essence of the Contract.

### **3. Release of Purchase Order:**

Purchase Order shall be issued to the successful bidder only after furnishing Security Deposit and execution of the Agreement, with Tamil Nadu Text Book and Educational Services Corporation as per clause 28 and 29 of the Instructions to Bidders.

### **4. Technical Specifications:**

The boxes of Wooden Colour Pencils supplied by the Successful Tenderer shall conform to the technical specifications in **Annexure I to III** of the Tender Document.

### **5. Supply:**

5.1. Supply of all the ordered boxes of Wooden Colour Pencils commensurating with the technical specifications in Annexure I and the specifications of the Model of Wooden Colour Pencils prescribed in Annexure II and III shall be made ***within sixty days*** from the date of issue of purchase order or date of acceptance of samples whichever is later. The entire supply shall be completed within the time schedule specified in the purchase order.

5.2. The entire quantity of the quality Wooden Colour Pencils shall be delivered at the designated locations in each Block Head Quarters of each District in the State of Tamil Nadu in good condition. The transit / Freight Charges, Insurance, all the Taxes, loading and unloading charges and all other incidental charges for the supply and delivery of the ordered goods in good condition to the designated locations shall be borne by the Successful Tenderer at his risk and cost.

5.3. In case of the Successful Tenderers from the states other than Tamil Nadu, it shall be their responsibility to get necessary interstate permit for the delivery of the ordered goods in time.

5.4. If the successful Tenderer is from the outside the State of Tamil Nadu, the tenderer should set up a local office in Chennai to ensure service.

**6. Sample Selection and Testing:**

**6.1. Before Supply:**

The Successful Tenderer shall submit untested samples of the three boxes of Wooden Colour Pencils i.e. finished products manufactured as per the technical specifications in the Tender Document to the Corporation within 7 days from the date of Letter of Acceptance (LOA) in adherence of the visual appearance and dimension of Wooden Colour Pencils.

**6.2. Pre - Despatch Inspection:**

- a) Pre-Despatch Inspections are generally conducted at the premises of the Successful Tenderer's manufacturing unit.
- b) The Successful Tenderer shall intimate the Corporation about the readiness of the supplies for the purpose of Inspection.
- c) 3 Boxes of samples of every lot representing 20,000 Boxes of Wooden Colour Pencils shall be taken at random by the representative of the Corporation and out of which one (1) Box of Wooden Colour Pencils shall be subject to the Lab Tests and clearance will be issued accordingly.
- d) The samples shall conform to the requirements of quality, colour, shade, size, dimension and weight as stipulated in the Technical Specification and the Model in the relevant Annexures in the Tender Document. Otherwise the entire lot shall be rejected.

- e) The cost of all the above tests including the freight charges, traveling expenses and incidental expenses shall be borne by the Successful Tenderer.
- f) If any substandard raw materials are found to be used by the Successful Tenderer, the Corporation without prejudice to any other action that may be taken against the Successful Tenderer shall terminate the Contract.

**6.3. After Supply:**

- a) It shall be the responsibility of the Successful Tenderer to ensure that the Wooden Colour Pencils supplied and delivered by him are in good condition.
- b) Random samples of the Wooden Colour Pencils supplied shall be tested by the Corporation in any of the accredited laboratory for its suitability and utility with reference to the specifications given in Annexure I to III. The Delivery and Acceptance certificates will be issued by the Assistant Elementary Education Officers / District Education Officers if the Successful Tenderer supplies and delivers the ordered quantity of Wooden Colour Pencils intact in time in full at the designated destinations.
- c) The testing charges for the post supply samples have to be borne by the successful Tenderer. The total inspection charges and sample testing charges for pre and post supply shall be deducted from the bill of the successful Tenderer.

**7. Insurance:**

The delivery of the Quality - Tested goods in fully packed and labeled condition as per the statutory norms and the specifications given in the Tender Document to the designated destinations in time shall be the responsibility of

the Successful Tenderer. The transit loss / theft / pilferage / damage of the goods under any circumstance shall be the liability of the Successful Tenderer. Insurance and transit insurance of the goods shall be the liability of the Successful Tenderer.

**8. Packing and Labelling:**

8.1. 6 Pieces of Wooden Colour Pencils shall be packed in two rows in a Carton Box of appropriate size.

8.2. 32 Boxes of Wooden Colour Pencils shall be packed in a corrugated box with sufficient buffer to avoid any breakage during transit.

8.3. The words 'Department of School Education' shall be printed on each Wooden Colour Pencil.

8.4. Each corrugated box shall be labelled and the label shall contain the following: NOT FOR SALE, SCHEME OF SUPPLY OF COST-FREE WOODEN COLOUR PENCILS TO SCHOOL CHILDREN by the Department of School Education, Government of Tamil Nadu, Successful Tenderer's Company Code No., Quantity, Serial Number and the Date, Month and Year of manufacturing of the Wooden Colour Pencils.

**9. Replacement:**

The quantity of Wooden Colour Pencils supplied by the Successful Tenderer shall be in accordance with the Specifications as in the Annexure I to III. If any defect is found pursuant to the pre-supply and post-supply laboratory tests in respect of the raw materials or the finished product of the Wooden Colour Pencils, the entire lot shall be rejected. The Successful Tenderer shall replace the rejected items with the new ones as per the instructions of the Corporation.

**10. Payment Terms:**

a) No advance payment shall be made or no letter of credit shall be accepted.

b) The Successful Tenderer shall raise the bill only after completion of supply and delivery in all the Blocks in each District as a whole in bulk.

No Bill shall be admitted from the Successful Tenderer who fails to effect

the supply and delivery of the Wooden Colour Pencils to all the Blocks in each District as per the Purchase Order in time.

- c) The bill raised by the Successful Tenderer shall have all Registration Numbers printed on the Bill. The validity of the Tax Registration during the currency period of the Contract shall be the sole responsibility of the Successful Tenderer.
- d) The Successful Tenderer shall submit the delivery report online first which shall be followed by hard copy. The Corporation shall process the bill for payment of 80% of the bill only after completion of the supply of the entire quantity in a District. Based on the certificates issued by the Assistant Elementary Education Officers / District Education Officers and after the receipt of certificate of the testing of the random samples of the supplied Wooden Colour Pencils issued by the Lab as per Clause 6.3.(b) of Special Terms and Conditions of the Tender, the bills will be admitted. The Corporation shall settle 80% of the bill within a reasonable time after receipt of the hard copy of the delivery notes and the afore-said Certificates of Acceptance and Lab Tests.
- e) Out of the remaining 20% of the bill, 10% of the bill shall be settled after the effective performance of the Contract in full to the entire satisfaction of the Corporation.
- f) The Corporation shall recover any dues from the Successful Tenderer if found to be recoverable on a later date in the audit even after final settlement of the Bill. The Successful Tenderer shall be liable to pay such dues to the Corporation.
- g) The remaining 10% of the Bill shall be paid after six months from the date of complete supply and distribution of the ordered quantity of Wooden Colour Pencils to the School Children in each Block and in each District as per the Purchase Order and the Delivery Schedule.

### **11. Liquidated Damages and Penalty:**

11.1. If the Successful Tenderer fails to deliver the boxes of Wooden Colour Pencils as per the Purchase Order and the Delivery Schedule specified by the Corporation, the Corporation shall have the right to impose **penalty of 1%** of

the value of the delayed supply for every week of delay or part thereof after the due date of delivery for a period of **Two weeks** and thereafter at the rate of 3% of the value of the delayed supply for each Week of delay or part till completion. Maximum penalty shall be limited to 10% of the final contract value. The Corporation shall have the right to make purchase from outside at higher rates if the delay continues even after four weeks for which penalty is imposed on the Successful Tenderer and the loss sustained by the Corporation to this effect shall be deducted from the bill of the Successful Tenderer and / or from the Security Deposit of the Successful Tenderer.

11.2. The Corporation shall have the right to terminate the Contract of the Successful Tenderer who fails to deliver the boxes of Wooden Colour Pencils in full as per the Purchase Order and the Delivery Schedule.

11.3. The Corporation shall have the right to place the Purchase Order with the other eligible Tenderer(s) if the supply is delayed beyond four weeks after the due date and it shall be at the cost and consequences of the Successful Tenderer who is in default. The Corporation also reserves the right to take any other action against the Successful Tenderer in default for any loss sustained by the Corporation.

11.4. If the delay continues even after the period of 50% of original supply period, the contract is liable to be cancelled at the discretion of the Managing Director in addition to imposing of a penalty of 5% of the value of delayed supply irrespective of the 10% of penalty already provided for in clause 11.1 of the special conditions of the contract.

11.5. The Successful Tenderer shall not manufacture, market, sell or supply the Wooden Colour Pencils manufactured, packed and labelled as per the Technical specifications in the Tender Document exclusively for distribution among the School Children studying in Government and Aided schools in Tamil Nadu. The Corporation shall impose penalty of not less than Rs.5,00,000/- (Rupees Five Lakh Only) every time for violation of the aforesaid condition. The penalty shall be in addition to the Civil and Criminal action taken by the Corporation against such Successful Tenderers in default. The Corporation shall have the right to blacklist such Successful



Tenderers from participating in the subsequent Tenders of the Corporation for a minimum period of three years.

11.6 The Corporation shall have the right to blacklist the Successful Tenderer for breach of any Conditions and Terms of the Tender / Agreement at any point of time.

11.7. If at any time before the acceptance of tender, the Tender Accepting Authority receives information that a tenderer who has submitted tender has been banned by any Procuring Entity, the Corporation shall not accept the tender of the tenderer even if it may be the lowest tender.

**12. Termination of Contract:**

**12.1. Termination For Default:**

- a) The Corporation may, without prejudice to any other remedy for breach of Contract by the Successful Tenderer, terminate the Contract in whole or part, by a 15 days' written notice of breach of Contract to the Successful Tenderer,
  - i. if the Successful Tenderer fails to deliver any or all of the goods within the time schedule specified in the Purchase Order, or within any extension thereof granted by the Corporation,
  - ii. if the Successful Tenderer fails to perform any of the obligation(s) under the Contract;
  - iii. if the Successful Tenderer is found to have involved in fraudulent, corrupt and unfair practices in competing for or in executing the Contract.
- b) If the Corporation terminates the Contract in whole or in part, the Corporation may procure, upon such terms and in such manner as it deems appropriate, the goods similar to those supplied and delivered and in that case the Successful Tenderer whose contract is terminated in whole or in part shall be liable to the Corporation for any additional costs involved in procuring and supplying the goods to the designated destinations. However, the Successful Tenderer shall continue the performance of the Contract to the extent not terminated. The Corporation reserves the right to take further action against the Successful Tenderer whose Contract has been terminated in whole or in part.

**12.2. Termination for Insolvency:**

The Corporation may at any time terminate the Contract by giving 15 days' written notice to the Successful Tenderer without compensation to the Successful Tenderer and without incurring any liability if the Successful Tenderer becomes bankrupt or otherwise insolvent. Such termination shall not prejudice or affect any right of action or remedy that has accrued or will accrue thereafter to the Corporation.

**12.3. Termination for Convenience:**

The Corporation may terminate the Contract in whole or in part at any time during the validity period of the Contract for its convenience by giving 15 days' written notice and without compensation to the Successful Tenderer. The notice of termination shall specify that termination is for the Corporation's convenience, the extent to which the Contract is terminated, and the date upon which such termination becomes effective. The termination of the contract is without prejudice to the penal consequences and damages for which the Successful Tenderer shall be liable for violation of the Contractual obligations.

**13. Force Majeure:**

13.1. Force Majeure means an event beyond the control of the Successful Tenderer and not involving the Successful Tenderer's fault of negligence and not foreseeable. Such event may include but are not limited to the acts of Nature such as fire, floods, epidemics, etc., and other events such as wars, revolutions, quarantine restrictions, etc.

13.2. If a Force Majeure situation arises, the Successful Tenderer shall promptly notify the Corporation of such conditions and the causes thereof through e.mail within 24 hrs of such event. The e.mail communication shall be followed by a report with documentary evidence to be sent to the Corporation within 3 days from the date of occurrence of such event. Unless otherwise directed by the Corporation in writing, the Successful Tenderer shall continue to perform his obligations under the Contract to a reasonably practical extent and shall seek all reasonable alternative means for effective performance of the Contract in time.

13.3. In the event of Force Majeure, the delivery period will be extended for a period equivalent to the period during which Force Majeure event was in existence. For this period the Successful Tenderer shall not be liable to pay penalty. Further if the performance in whole or part, of any obligation under this Contract is prevented or delayed by reason of Force Majeure for a period exceeding 21 days, the Corporation may at its option and discretion terminate the Contract.

13.4. The price quoted by the bidder and accepted by the Corporation shall remain fixed and firm during the extended period during which Force Majeure was in existence. Force Majeure shall not have any bearing on the price quoted by the Successful Tenderer in the Tender.

#### **14. Conciliation & Arbitration:**

##### **14.1. Conciliation:**

If any dispute or difference arises between the Corporation and a Successful Tenderer with regard to the Contractual obligations, the same shall be referred to a Conciliator and settled by Conciliation as per the provisions of The Arbitration and Conciliation Act, 1996. The sole Conciliator shall be nominated by the Managing Director of the Corporation. Conciliatory efforts are mandatory in tune with the Alternative Disputes Resolution (ADR) process before invoking the Arbitration Clause. The Conciliator shall endeavor to conclude his proceedings within three weeks from the date of reference of a dispute or claim to him.

##### **14.2. Arbitration:**

In case of any dispute or difference arising between the Corporation and the Successful Tenderer relating to any matter arising out of or connected with the Contract which still remains unsettled even after Conciliation, such dispute or difference shall be referred to the sole Arbitrator nominated by the Managing Director of the Corporation. The Arbitral proceedings shall be conducted in accordance with the provisions of the Arbitration and Conciliation Act, 1996. If the Arbitrator for any reason has to discontinue the Arbitration before completion of the arbitral proceedings, the Managing Director of the Corporation shall nominate another eligible and suitable person as Arbitrator and such Arbitrator may continue the proceedings from the stage at which his

predecessor has discontinued or may proceed de novo. The Arbitral Award shall be final and binding on both the Corporation and the Successful Tenderer. No part of the Contract shall be suspended by the Successful Tenderer on the ground of pendency of the Arbitral Proceedings.

The venue of Arbitration shall be at Chennai. The language to be used in the Arbitral proceedings shall be in English.

**15. Jurisdiction:**

The courts in the city of Chennai alone shall have the jurisdiction to try any matter or dispute or reference between the Corporation and the Successful Tenderers arising out of the Contract.

**6. LETTER OF THE TENDERER**

To

The Managing Director  
Tamil Nadu Text Book and Educational Services Corporation,  
Chennai- 600 006.

Sir,

I / We do hereby tender / offer to the Tamil Nadu Text Book and Educational Services Corporation for the Supply and Delivery of boxes of Wooden Colour pencils to the School Children in Tamil Nadu on Annual Rate Contract Basis conforming to the technical specifications and to the conditions stated in the annexed contract and specification and drawings attached here to.

I / We have understood that the requirement of the Corporation and noted the details of the materials to be supplied and have carefully understood the conditions of contract and the specification and drawing with all the stipulations of which I / We agree to comply.

I / We hereby undertake to complete delivery of the materials at the places mentioned in the specification, within the time limit specified by the Corporation.

I am / we are quite aware that quality of the materials and time of delivery are the essence of this contract and accordingly, I/we would adhere to the same.

I / We further agree that I / We would not withdraw this tender either in full or in part. If by chance, I/we have to withdraw the offer, I/we agree that the EMD paid will be forfeited by the Corporation, without any notice to me / us.

I / We affirm that in any previous tender to the Tamil Nadu Text Book and Educational Services Corporation, I/we have not committed any fraud by furnishing wrong information and the Corporation had not written to us alleging fraud in our transaction with the Corporation.

I / We further confirm that in case, any of the information noted above is found to be incorrect, I / We will be liable for any action under the terms of the tender / contract including termination of the contract and forfeiture of the Earnest Money / Security Deposit.

I / We hereby undertake and agree to pay the Security Deposit as per the tender conditions within **ten days** from the date of issue of Letter of Acceptance (LOA).

I / We undertake to sign the contract with the Corporation within **fifteen days** from the date of issue of Letter of Acceptance (LOA).

I / We further agree that the acceptance of the tender conditions would, by itself, constitute a valid and concluded contract binding on me/us, even if separate contract is not signed.

I / We further agree that in the event of my/our failing to deposit securities mentioned above or to produce the latest income tax and sales tax clearance certificate or to execute the Contract within the period of fifteen days as referred to above, the sum of Rs.1.27 lakhs deposited with the tender shall be forfeited by the Tamil Nadu Text Book and Educational Services Corporation and in addition, the Managing Director, Tamil Nadu Text Book and Educational Services Corporation, shall be entitled to cancel the contract and there upon arrange for any other person or persons to supply the materials herein before mentioned and I / We agree to be liable for all damages, losses, charges and expenses arising from or by reason of such failure on our part.

I / We hereby further agree and undertake that:

a. In case, there is any defect found in the Wooden Colour Pencils or in any part of the Wooden Colour Pencils delivered, I/we undertake to replace the same by a new one.

b. If the Wooden Colour Pencils delivered is found to have even the slightest damage, due to any reason like in the process of transportation, the material should be replaced by a new one.

I / We hereby declare that I / We agree to do the various acts, deeds and things referred to herein, for enabling the Corporation to procure the Wooden Colour Pencils conforming to specifications.

Having fully understood the tender conditions and the above undertaking in this letter, I/we sign this .....Day of .....at .....

Yours faithfully,

Authorized Signature :

Name & Title of Signatory:

.....

....

Name of the Bidder :

.....

Address : .....

**7. SPECIFICATIONS****ANNEXURE - I****TECHNICAL SPECIFICATIONS FOR WOODEN COLOUR PENCILS  
(BICOLOUR) - 2017-18**

SI.No	Property	Wooden Colour Pencils (Bicolour) size
1	Each Pencil shall have	Two Colour
2	No. of Shades	12 Nos.
3	Colour (6 pencils)	1. White and Black 2. Sky Blue and Dark Blue 3. Green and Light Green 4. Red and Orange 5. Yellow and Pink 6. violet and Brown
4	Shape of the Pencil	Hexagonal and both end pre sharpened
5	Length of the pencil (Two colour)	176 ± 2 mm
6	Diameter of the Colour Pencil	7.6 ± 0.2 mm
7	Length of the pencil (Each colour)	87 ± 2 mm
8	Diameter of the Lead	2.8 ± 0.1 mm
9	Net weight of 6 Wooden Colour Pencils with a Sharpener	30.8 ± 3 gms Net weight of sharpener : 2.8 ± 0.3 gms Net weight of 6 Wooden Colour Pencils: 28 ± 3 gms
10	Material	Rich of colour pigments bonded with wood
11	Other Items Sharpener	Length 29 ± 1 mm with Metal Blade and Metal Screw.  Body of the sharpener shall be made of high quality polystyrene and the blade shall be made of high speed carbon sheet with rust resistant coating. There shall be no lead breakage or crumbling of lead.
12	Packing	6 Wooden Pencils with 12 shades of colour arranged in one row in a carton box and separate space should be provided for sharpener in the same box.

**Note :**

With all the above specifications, the Double Edge Colour Pencil shall have the following performance features:

- Smooth and easy spread of colour
- The colour pencil shall be made up of wood. The wood shall be smooth enough for sharpening with a sharpener.
- Pencil lead shall be securely bonded to protect from breakage



## 8. DRAWINGS

### ANNEXURE - II

#### **MODEL OF WOODEN COLOUR PENCILS (BICOLOUR)** (3D Coloured Diagram with Specifications)



Shape – Hexagonal and both end pre sharpened

Material – Rich Colour Pigment bonded with wood

Length –  $176 \pm 2$  mm

Diameter of the pencil –  $7.6 \pm 0.2$  mm

Diameter of the lead -  $2.8 \pm 0.1$  mm

**ANNEXURE - III**

**WOODEN COLOUR PENCIL (BICOLOUR) WITH SHARPNER  
PACKING CARTON BOX DIMENSIONS (in mm)**

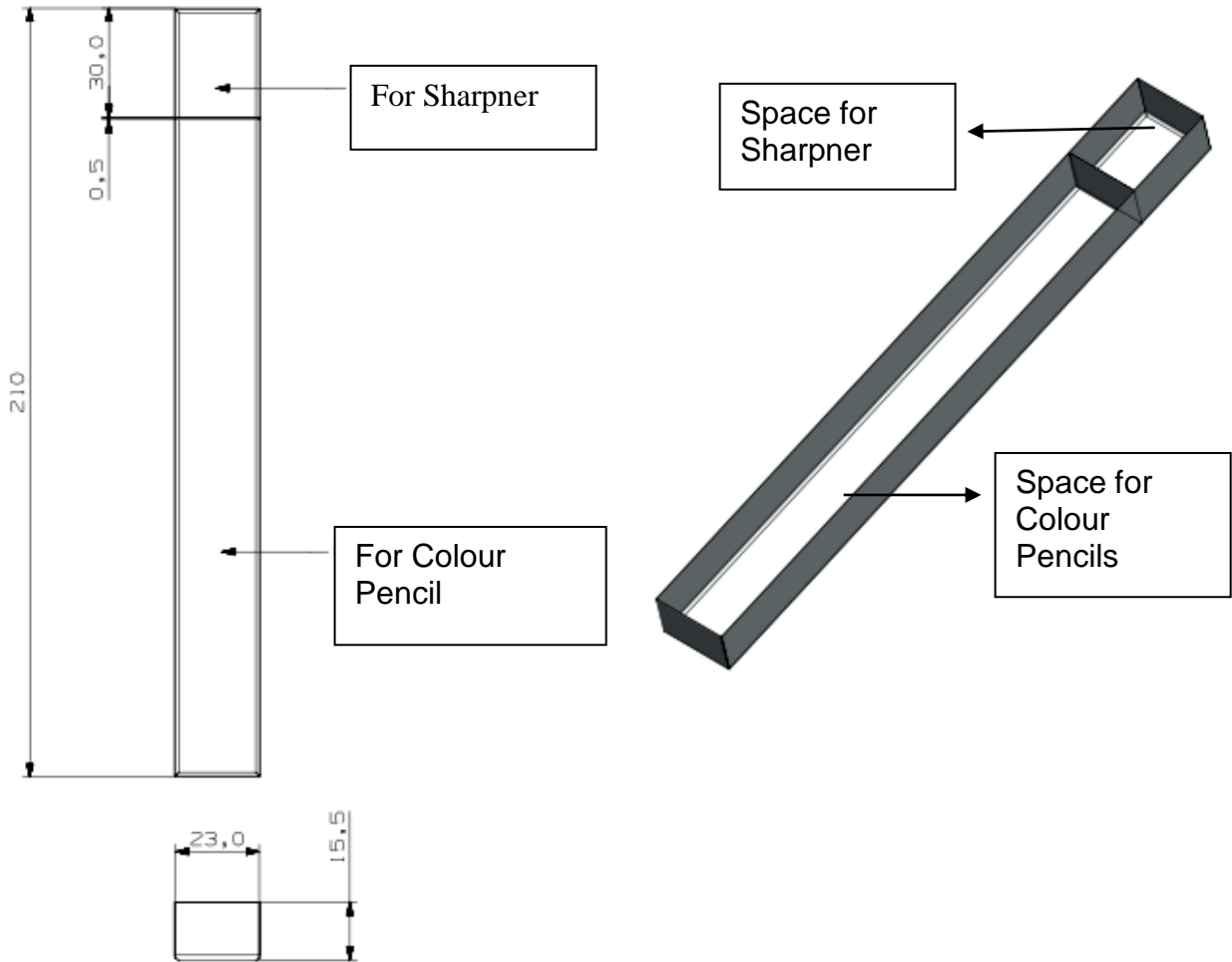

**VIEW OF PACKING CARTON BOX IN OPEN CONDITION  
DIMENSIONS (in mm)**

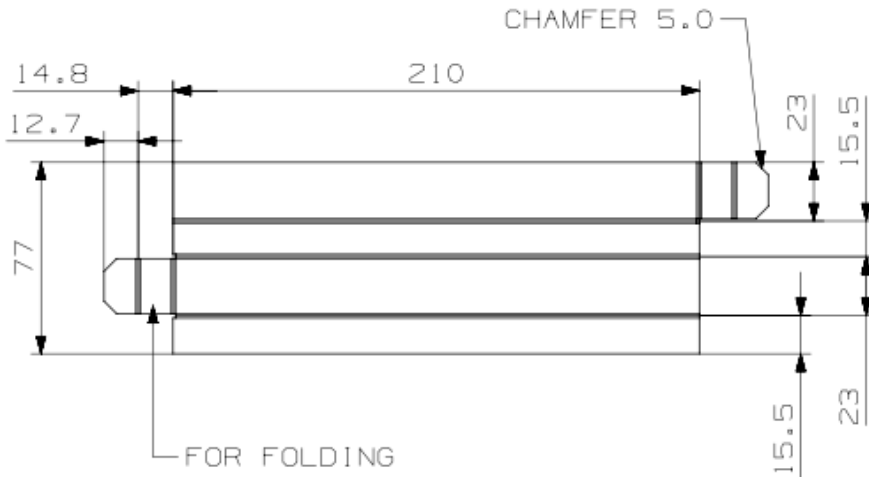

**CARTON BOX AFTER FOLDING**



**BOX MODEL OF WOODEN COLOUR PENCIL WITH SHARPNER**

(3D Coloured Diagram with specifications)



## 9. STATEMENTS AND DECLARATIONS

### ANNEXURE -IV

#### PROFILE OF THE TENDERER

The Tender shall furnish the following details without fail.

- a) Name of the Organization :
- b) Nature of the Organization :  
( i.e. Public Sector Undertaking / Public Ltd / Private Ltd Company)
- c) Number and Year of Registration /Incorporation :  
(copy of Certificate of Incorporation shall be enclosed)
- d) Address of the Registered Office of the Company / Firm with phone, Fax,  
and Email ID. :
- e) Address of the Manufacturing Unit with phone, Fax,  
and Email ID. :
- f) Audited annual report for the last three years :  
(copy of the same along with Technical Bid shall be enclosed).
- g) A copy of PAN Card attested by the Company Secretary or Managing  
Director or the Auditor shall be enclosed.

**Note:** The Tenderer shall enclose documentary proof for the above without fail.

**ANNEXURE - V****ANNUAL TURNOVER STATEMENT FOR SINGLE BIDDER**

The annual turnovers of M/s. .... for the past four years are given below and certified that the statement is true and correct.

<b>Sl.No.</b>	<b>Years</b>	<b>Turnover in lakhs (Rs.)</b>
1.	2012-2013	
2.	2013-2014	
3.	2014-2015	
4.	2015-2016	
	Total Turnover for three consecutive years	
	Average Turnover per year	

Date:

Seal:

**Signature of Tenderer  
with Seal**

**Signature of The Auditor /  
Chartered Accountant  
(Name in Capital with  
Registration Number)**



**ANNEXURE - VII**

Date:

**DECLARATION**

I / We ..... having the registered office at .....  
..... hereby declare that the Firm / Company or its Partners  
/ Shareholders have not been blacklisted by the Corporation or any  
Undertaking / Corporation of the Central / State Governments.

**Signature of the Tenderer  
with Seal**



**ANNEXURE - VIII**

Date :

**DECLARATION FORM**

I/We .....

having the registered office at..... declare that I/we have carefully read all the terms and conditions of Tender floated by the Tamil Nadu Text Book and Educational Services Corporation, Chennai vide Tender Ref.No.7423/C1/2016 for the purchase of 15.48 **Lakh** boxes of Wooden Colour Pencils strictly conforming to the specifications as given in the Tender Document and I / we shall abide by all the conditions set forth therein. I/we also undertake to take back the rejected defective and the test-failed Wooden Colour Pencils at our risk & cost and replace the same within the stipulated time.

**Signature of the Tenderer  
with Seal**

**ANNEXURE -IX****SELF CERTIFICATION OF QUALITY**

Certified that the quality of three boxes of samples of Wooden Colour Pencils submitted with the Tender conforms to the technical specifications prescribed in **Annexure I – III**

**A. Minimum Specification:**

<b>Description</b>	<b>Required Specification</b>	<b>Whether samples conform to Specifications (Yes / No)</b>
Wooden Colour Pencils	As per specifications as given in Annexure – I – III	

**Signature of the Tenderer  
with Seal**

**ANNEXURE -X**

**CERTIFICATE**

It is certified that I / We ..... have offered to supply a quantity of ..... Boxes of Wooden Colour Pencils within a period of ..... days.

I am aware that as per Tender conditions, the minimum production capacity is 5,000 Boxes of Wooden Colour Pencils per day.

**Signature of the Tenderer  
with Seal**

**ANNEXURE - XI**

Date :

**CERTIFICATE**

I/we having office at ..... declare that the tender forms downloaded from the website [www.tenders.tn.gov.in](http://www.tenders.tn.gov.in) have not been tampered with / modified in any manner. In case, if the same is found to be tampered with / modified, my / our Tender shall be summarily rejected.

**Signature of the Tenderer  
with Seal**

**ANNEXURE - XII**

**SAMPLE FORMAT FOR AVAILABILITY OF CREDIT FACILITIES -**

**Nationalised/Scheduled Bank Certificate**

This is to certify that M/s . . . . . is a reputed company with a good financial standing.

If the contract for the work, namely . . . . . is awarded to the above firm, we shall be able to provide overdraft/credit facilities to the extent of Rs. . . . . to meet their working capital requirements for executing the above contract.

Signature

Name

Designation

Address of the Bank

**ANNEXURE - XIII**

**BANK GUARANTEE FOR SECURITY DEPOSIT**

To: \_\_\_\_\_ [name of Employer]  
\_\_\_\_\_ [address of Employer]

WHEREAS \_\_\_\_\_ [name and address of Successful Tenderer] (hereinafter called "the Successful Tenderer") has undertaken, in pursuance of Tender No.

\_\_\_\_\_ dated \_\_\_\_\_ to execute \_\_\_\_\_ [name of Contract and brief description of Works] (hereinafter called "the Contract");

AND WHEREAS it has been stipulated by you in the said Contract that the Successful Tenderer shall furnish you with a Bank Guarantee by a recognized bank for the sum specified therein as security for compliance with his obligations in accordance with the Contract;

AND WHEREAS we have agreed to give the Successful Tenderer such a Bank Guarantee;

NOW THEREFORE we hereby affirm that we are the Guarantor and responsible to you, on behalf of the Successful Tenderer, up to a total of

\_\_\_\_\_ [amount of guarantee]<sup>1</sup> \_\_\_\_\_ [in words], such sum being payable in the types and proportions of currencies in which the Contract Price is payable, and we undertake to pay you, upon your first written demand and without cavil or argument, any sum or sums within the limits of \_\_\_\_\_ [amount of guarantee]<sup>1</sup> as aforesaid without your needing to prove or to show grounds or reasons for your demand for the sum specified therein.

We hereby waive the necessity of your demanding the said debt from the Successful Tenderer before presenting us with the demand.

We further agree that no change or addition to or other modification of the terms of the Contract or of the Works to be performed there under or of any of the Contract documents which may be made between you and the

Successful Tenderer shall in any way release us from any liability under this guarantee, and we hereby waive notice of any such change, addition or modification.

This guarantee shall be valid until 18 Calendar months from the date of issue of Bank Guarantee.

Signature and seal of the guarantor \_\_\_\_\_

Name of Bank \_\_\_\_\_

Address \_\_\_\_\_

Date \_\_\_\_\_

- <sup>1</sup> An amount shall be inserted by the Guarantor, representing the percentage of the Contract Price specified in the Contract including additional security for unbalanced Bids, if any and denominated in Indian Rupees.

**ANNEXURE – XIV****AGREEMENT FORM**

(To be filled by the tenderer in a non-judicial stamp paper of value not less than Rs.20/-)

THIS AGREEMENT made the ..... day of ....., 2016 between .....(Name and Address of **Purchaser**) represented by the Secretary ..... (herein after “the **Purchaser**”) of one part and .....(Name and Address of Supplier) ..... (hereinafter “the Supplier”) represented by ..... (Name of the Authorized Signatory and Designation), Aged ..... years, residing at ..... (Full Residential Address of the Signatory) of the other part:

WHEREAS the **Purchaser** is desirous that certain Goods and ancillary services should be provided by the Supplier, viz., ..... (Brief Description of Goods and Services) and ..... has accepted a bid by the Supplier for the supply of those goods and services in the sum of ..... (Contract Price in Words and Figures) (herein after “the Contract Price”).

**NOW THIS AGREEMENT WITNESSETH AS FOLLOWS:**

1. In this Agreement words and expressions shall have the same meanings as are respectively assigned to them in the Conditions of Contract referred to.
2. The following documents shall be deemed to form and be read and constructed as part of this Agreement, viz.:
  - (a) Bid Form and Price Schedule submitted by the Bidder;
  - (b) Schedule of Requirements;
  - (c) Technical Specifications;
  - (d) Instructions to Bidders;
  - (e) Special Conditions of Contract; and
  - (f) Letter of Acceptance
  - (g) Purchase Order
  - (h) All Addendum issued and replies to queries and any other clarifications issued by the Corporation as forming part of the contract.



3. In consideration of the payments to be made by the **Purchaser** to the Supplier as hereinafter mentioned, the Supplier hereby covenants with the **Purchaser** to provide the Goods and Services and to remedy defects therein in conformity in all respects with the provisions of the Contract.

4. The **Purchaser** hereby covenants to pay the Supplier in consideration of the provision of the Goods and Services and the remedying of defects therein, the Contract Price or such other sum as may become payable under the provisions of the Contract at the times and in the manner prescribed by the Contract.

**BRIEF PARTICULARS OF THE GOODS AND SERVICES WHICH SHALL BE SUPPORTED / PROVIDED BY THE SUPPLIER ARE:**

-----  
-----

**IN WITNESS** whereof the parties hereto have caused this Agreement to be executed in accordance with their respective laws the day and year first above written.

Signed, Sealed and Delivered by the said ..... (For the **Purchaser**)

in the presence of ..... Signed, Sealed and Delivered by the said .....(For the Supplier) (Signature, Name, Designation and Address with Office seal) in the presence of .....

- 1) (Signature, Name and Address of witness)
- 2) (Signature, Name and Address of witness)

**PART - B****10. PRICE BID****(TO BE FURNISHED IN PART - B COVER)****SCHEDULE OF RATES OFFERED FOR SUPPLY OF BOXES OF WOODEN COLOUR PENCILS EACH CONTAINING 6 PIECES (Bicolour) AS PER SPECIFICATIONS (As per Annexure-I)**

Sl. No.	Details	Rate per box inclusive of cost of delivery of Box of Wooden Colour Pencils at designated locations	
		Amount in Figure	Amount in Words
1	Basic Cost		
2	Excise Duty		
3	TNVAT		
4	CST		
5	Others (to be specified)		
	<b>TOTAL</b>		

**Signature of the Tenderer  
with Seal**